

ALUMINUM FOIL PACKAGING EQUIPMENT
INDUSTRY LEADING BRAND
铝箔包装设备行业领导品牌



ZONGBOU
中箔

浙江中箔科技有限公司
ZHEJIANG ZHONGBO TECHNOLOGY CO.,LTD.

浙江省瑞安市南滨街道林垟工业区八达路68号
No.68 Bada Rd, Linyang Industrial Zone,
Nanbin Subdistrict, Ruian City, Zhejiang Province

86-13967702811 86-13958859570
86-0577-65595666
86-0577-65592060
willzhao@zongbou.com Ricky@zongbou.com

www.zongbou.com

OUTSTANDING GLOBAL
PACKAGING
SOLUTIONS PROVIDER

优秀的全球铝箔包装设备供应商

- AFC Making Machine
铝箔容器生产线
- Mould
铝箔容器模具
- Aluminum Foil Containers
铝箔包装容器



ZHEJIANG ZHONGBO TECHNOLOGY CO.,LTD.

ZONGBOU
中箔

ALUMINUM FOIL CONTAINER MAKING MACHINE SOLUTION

铝箔容器设备解决方案



AFC Making Machine
铝箔容器生产线



Mould
铝箔容器模具



Aluminum Foil Container Supporting Equipment
铝箔容器配套设备



行业先行者

浙江中箔科技有限公司致力于为全球铝箔包装行业在新时代转型升级提供整体解决方案。主要生产铝箔容器生产线、铝箔容器模具、铝箔送料机、铝箔容器堆垛机、废铝打包机等。

长久以来，我们在设计、制造、维修等专业技术领域积累了丰富的行业经验。公司“以质量求生存，以客户为中心”的宗旨，不断完善产品结构，全力打造成为铝箔包装行业整体解决方案首选供应商。

Industry Pioneer

Zhejiang ZHONGBO technology Co.,Ltd. is committed to providing overall solutions for the transformation and upgrading of the global aluminum foil packaging industry in the new era. We mainly produce aluminum foil container production line, aluminum foil container mould, aluminum foil feeder, aluminum foil container stacker, aluminum scrap baler and so on.

For a long time, we have accumulated rich industrial experience in design, manufacture, maintenance and other professional and technical fields. With the tenet of "Survive on quality, take customers as the center", we are constantly improving our product structure and making every effort to become the preferred supplier of overall solutions for the aluminum foil packaging industry.



VISION 愿景
Becoming a leader in the aluminum foil packaging industry
成为铝箔包装行业的领航者



VALUES 价值观
Internationalization, Integrity, Innovation
国际化、诚信、创新

We provide one-stop Overall solution

我们提供一站式整体解决方案

AFC Making Machine

铝箔容器生产线

- 按照您的生产需求，我们为您提供多种规格的设备，主要适用于生产加工一次性有皱和无皱铝箔容器、铝箔餐盒、铝箔盖等食品级包装产品,铝箔厚度适用范围为0.025-0.3mm。

According to your production requirements, we provide you with a variety of specifications of equipment, mainly for the production and processing of disposable wrinkled and wrinkle-free aluminum foil containers, aluminum foil lunch boxes, aluminum foil lids and other food-grade packaging products, the thickness of aluminum foil for the applicable range of 0.025-0.3mm.



Aluminum Foil Container Machine
铝箔餐盒成型机

AFC production line supporting equipment

铝箔容器生产线配套设备

- 包含铝箔送料机、铝箔容器堆垛机、废铝打包机等。
- Includes aluminum foil feeder, aluminum foil container stacker, scrap aluminum baler, etc.



铝箔送料机
Aluminum Foil Feeder

铝箔容器堆垛机
Aluminum Foil Container Stacker

废铝打包机
Scrap Aluminum Baler

Mould

铝箔容器模具

- 模具可按照您的需求进行定制，采用加厚特制优质模具钢，严格按照欧洲模具钢材标准，符合食品免洗容器生产卫生需求。
- Moulds can be customized according to your needs, using thickened special high-quality mold steel, in strict accordance with the European mold steel standards, in line with the hygienic requirements for the production of foodstuffs no-wash containers.

- 核心部件均由自有CNC和中慢丝线切割机加工，热处理及铝件加表面硬度处理更耐磨。

The core parts are all processed by our own CNC and medium and slow wire cutting machines, heat treatment and aluminum parts with surface hardness treatment are more wear-resistant.

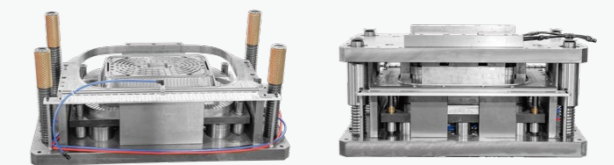

Aluminum Foil Container

铝箔包装容器

- 铝箔包装容器具有化学稳定、无毒无味、可无限循环再利用等化学特点,以及具备微波炉、可电磁炉、可烤箱蒸箱、可明火等耐高温加热特点。

Aluminum foil packaging containers have chemical characteristics such as chemically stable, non-toxic, tasteless, and infinitely recyclable; as well as high temperature resistance heating characteristics such as microwaveable, electromagnetic, ovenable steamer, and open flame.

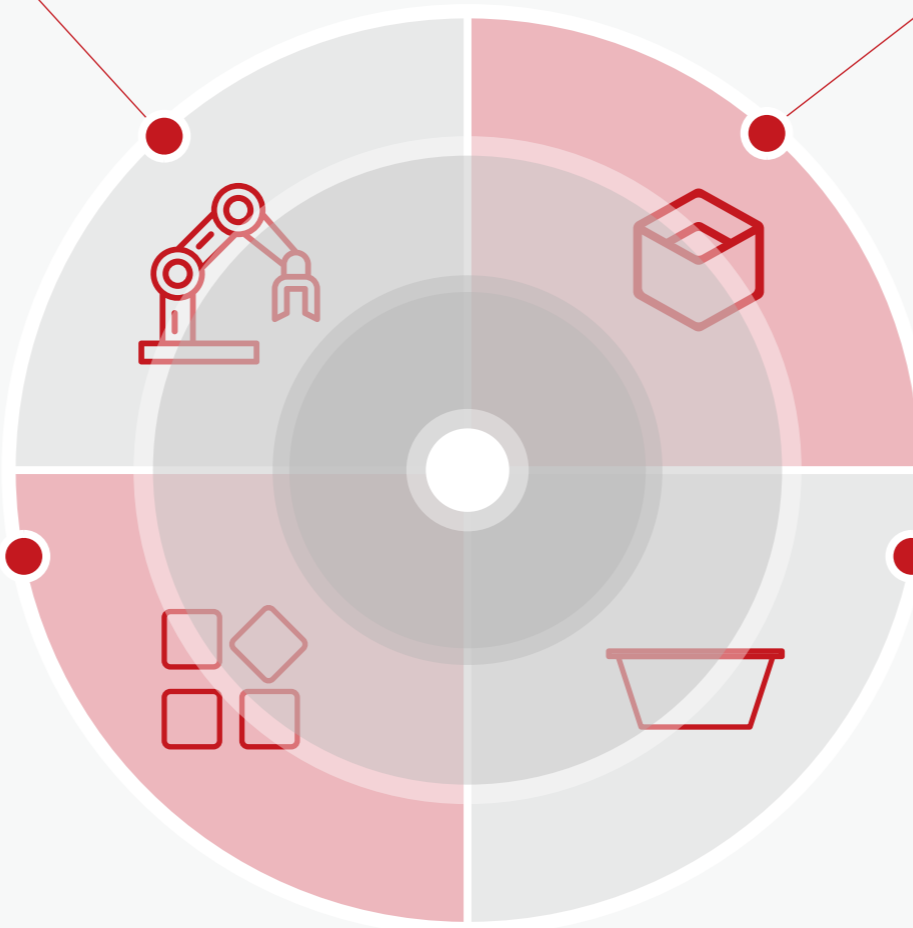

ZBFC-12

Aluminum Foil Container

铝箔餐盒成型机



STRUCTURE 结构



液压成型 Hydraulic punching system



伺服送料 Servo motor controlled feeding

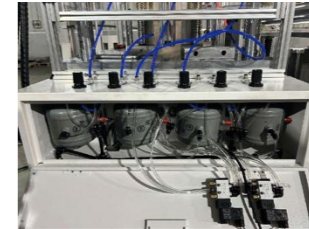

电气规范配置 Electric part



磁粉张力控制, 配自动过油
Magnetic powder tension control system with auto oiling



伺服送料
Servo motor controlled feeding

LAYOUT 摆放图

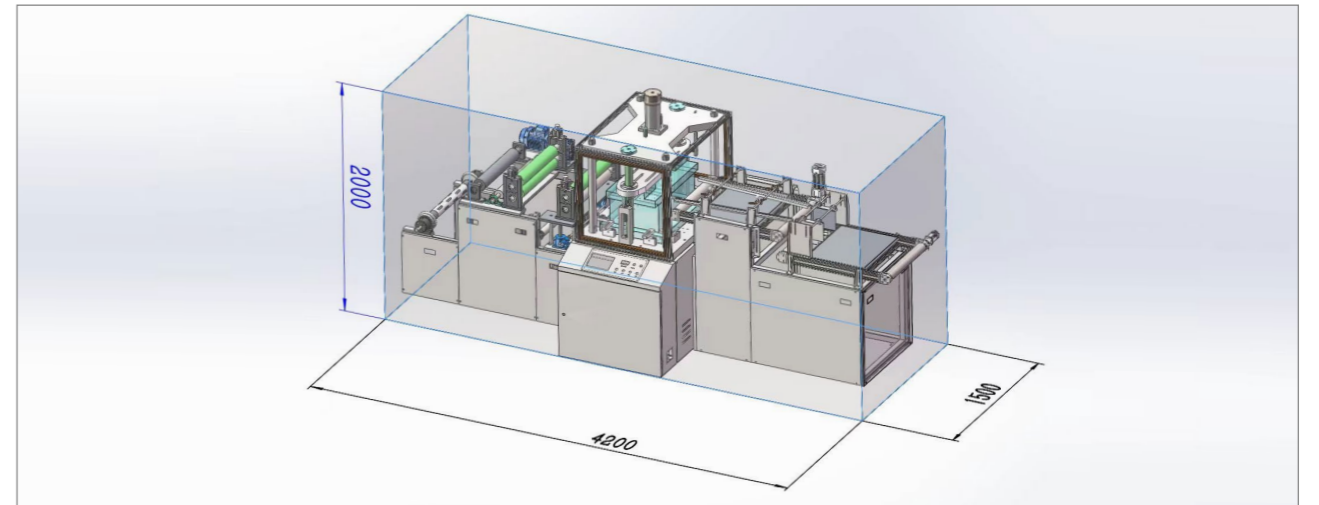

MAIN TECHNICAL PARAMETERS 主要技术参数

型号	Model	ZBFC-12
公称力	Nominal Force	120KN
行程范围	Stroke Range	150mm
冲压速度范围	Stamping Speed Range	20-40times/min.
工作台板尺寸	Table Plate Size	L780xW780
最大装模尺寸	Maximum Mold Size	L780xW780xH420mm
最大送料宽度	Maximum Feed Width	600mm
最大铝箔卷外径	Maximum Aluminum Foil Roll Outer Diameter	650mm
堆垛机输送带尺寸	Stacker Conveyor Size	L600xW900mm
设备尺寸	Machine Size	4200x1500x2000mm
设备重量	Machine Weight	2,500KGS



ZBFC-45/63

Aluminum Foil Container Machine

铝箔餐盒成型机

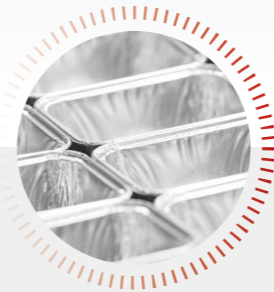

EQUIPMENT CHARACTERISTICS 设备特点

- 采用悬臂式可转动集成触摸屏操控结构：比传统移动操作台更灵活、更安全、不占空间。
- 触摸屏可远程监测设备运行状态，以及在线更新程序。
- 升降电缸采用SMC伺服控制
- 工作台板采用分体8组升降钢珠：可实现1个工人15分钟内完成一次卸模具换装模具

- Adopts cantilevered rotatable integrated touch screen control structure: more flexible, safer and less space-consuming than the traditional mobile operator station.
- The touch screen can remotely monitor the running status of the equipment and update the program online.
- The lifting cylinder adopts SMC servo control.
- The working table plate adopts 8 sets of lifting balls: it can realize one worker to finish unloading and changing molds within 15 minutes.

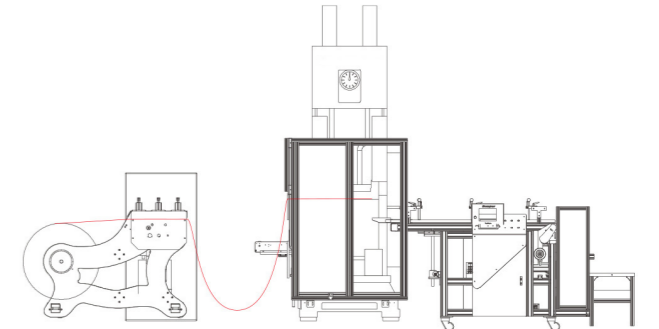
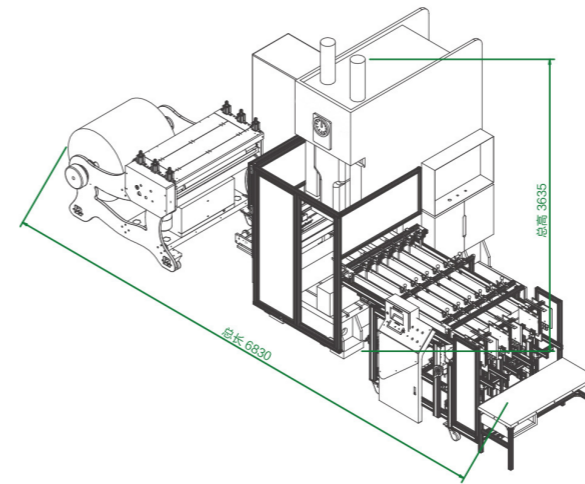

MAIN TECHNICAL PARAMETERS 主要技术参数

型号	Model	ZBFC-45	ZBFC-63
公称力	Nominal Force	450KN	630KN
主电机功率	Main Motor Power	7.5KW	11KW
行程范围	Stroke Range	150-220mm	150-300mm
冲压速度范围	Stamping Speed Range	35-75times/min.	30-80times/min.
工作台板尺寸	Table Plate Size	L810xW440mm,2sets movable plate	L1100xW920mm,2sets movable plate
最大装模尺寸	Maximum Mold Size	L810xW370xH270mm	L1200xW850xH450mm
最大送料宽度	Maximum Feed Width	700mm	900mm
最大铝箔卷外径	Maximum Aluminum Foil Roll Outer Diameter	600-1500mm	600-1500mm
堆垛机输送带尺寸	Stacker Conveyor Size	L2000xW700mm	L2000xW900mm
最小可堆垛尺寸	Minimum Stackable Size	120x120mm	120x120mm
产品堆垛尺寸	Product Stacking Dimensions	One lane:L500xW800xH350mm Two lane: L500xW400xH350mm Three lane:L500xW250xH350mm Four lane: L500xW190xH350mm	
设备尺寸	Machine Size	7000x2400x2750mm	7100x2500x3500mm
设备重量	Machine Weight	8,000KGS	11,500KGS

ZBFC-80/130

Aluminum Foil Container Machine

铝箔餐盒成型机



EQUIPMENT CHARACTERISTICS 设备特点

- 压力机润滑采用自动循环电动稀油润滑系统：递进式润滑油分配器带润滑故障检测开关，确保润滑充分均匀，避免无油运行对导轨的损伤。
- 采用悬臂式可转动集成触摸屏操控结构，触摸屏可远程监测设备运行状态，以及在线更新程序。
- 铝箔送料采用伺服系统：可适应不同厚度和宽度的铝箔材料快速更精准的完成送料，曲线输出扭矩让铝箔平稳不抖动。
- 采用H型八面导轨和优异动态平衡设计，低震动和低噪音
- 采用高度灵敏、可靠的意大利OMPI干式离合器和日本TACO双联电磁阀：确保压力机滑块运转及时停止的精确性和安全性。

- Press lubrication adopts automatic circulation electric thin oil lubrication system: progressive lubrication oil distributor with lubrication fault detection switch ensures sufficient and even lubrication and avoids damage to the guide rail by running without oil.
- The press adopts cantilever type rotatable integrated touch screen control structure, the touch screen can remotely monitor the running status of the equipment and update the program online.
- Aluminum foil feeding adopts servo system: it can adapt to different thickness and width of aluminum foil material to complete the feeding quickly and more accurately, and the curve output torque makes the aluminum foil smooth and not shaking.
- Adopting H-type eight-face guide rail and excellent dynamic balance design, low vibration and low noise.
- Adopting highly sensitive and reliable Italian OMPI dry clutch and Japanese TACO duplex solenoid valve: to ensure the accuracy and safety of the press slide running and stopping in time.

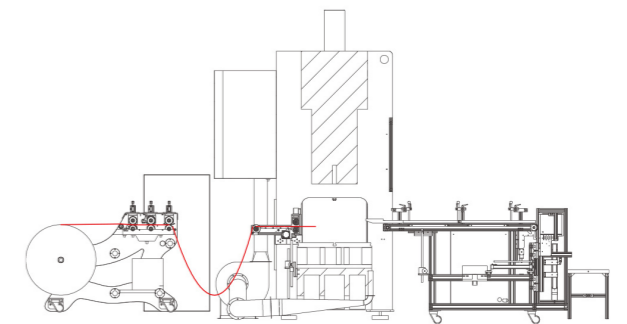
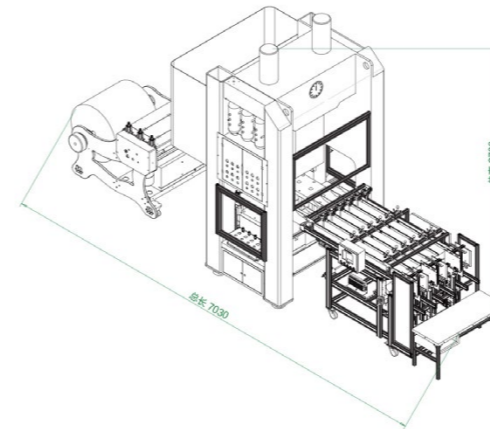

MAIN TECHNICAL PARAMETERS 主要技术参数

型号	Model	ZBFC-80	ZBFC-130
公称力	Nominal Force	800KN	1300KN
主电机功率	Main Motor Power	18.5KW	18.5KW
行程范围	Stroke Range	150-260mm	150-260mm
冲压速度范围	Stamping Speed Range	35-80times/min.	30-80times/min.
工作台板尺寸	Table Plate Size	L1480xW900mm,2sets movable plate	L1700xW900mm,2sets movable plate
最大装模尺寸	Maximum Mold Size	L1450xW850xH500mm	L1650xW850xH500mm
最大送料宽度	Maximum Feed Width	1220mm	1420mm
最大铝箔卷外径	Maximum Aluminum Foil Roll Outer Diameter	600-1500mm	600-1500mm
堆垛机输送带尺寸	Stacker Conveyor Size	L2000xW1300mm	L2000xW1500mm
最小可堆垛尺寸	Minimum Stackable Size	100x100mm	100x100mm
产品堆垛尺寸	Product Stacking Dimensions	Three lane: L600xW350xH350mm Four lane: L600xW250xH350mm Five lane: L600xW210xH350mm Six lane: L600xW170xH350mm	Four lane: L600xW300xH350mm Five lane: L600xW240xH350mm Six lane: L600xW200xH350mm Seven lane:L600xW170xH350mm
设备尺寸	machine Size	8000x2500x3650mm	7030x2800x3730mm
设备重量	Machine Weight	13,500KGS	17,500KGS

ZBF-S

Unwinding system

铝箔放卷机

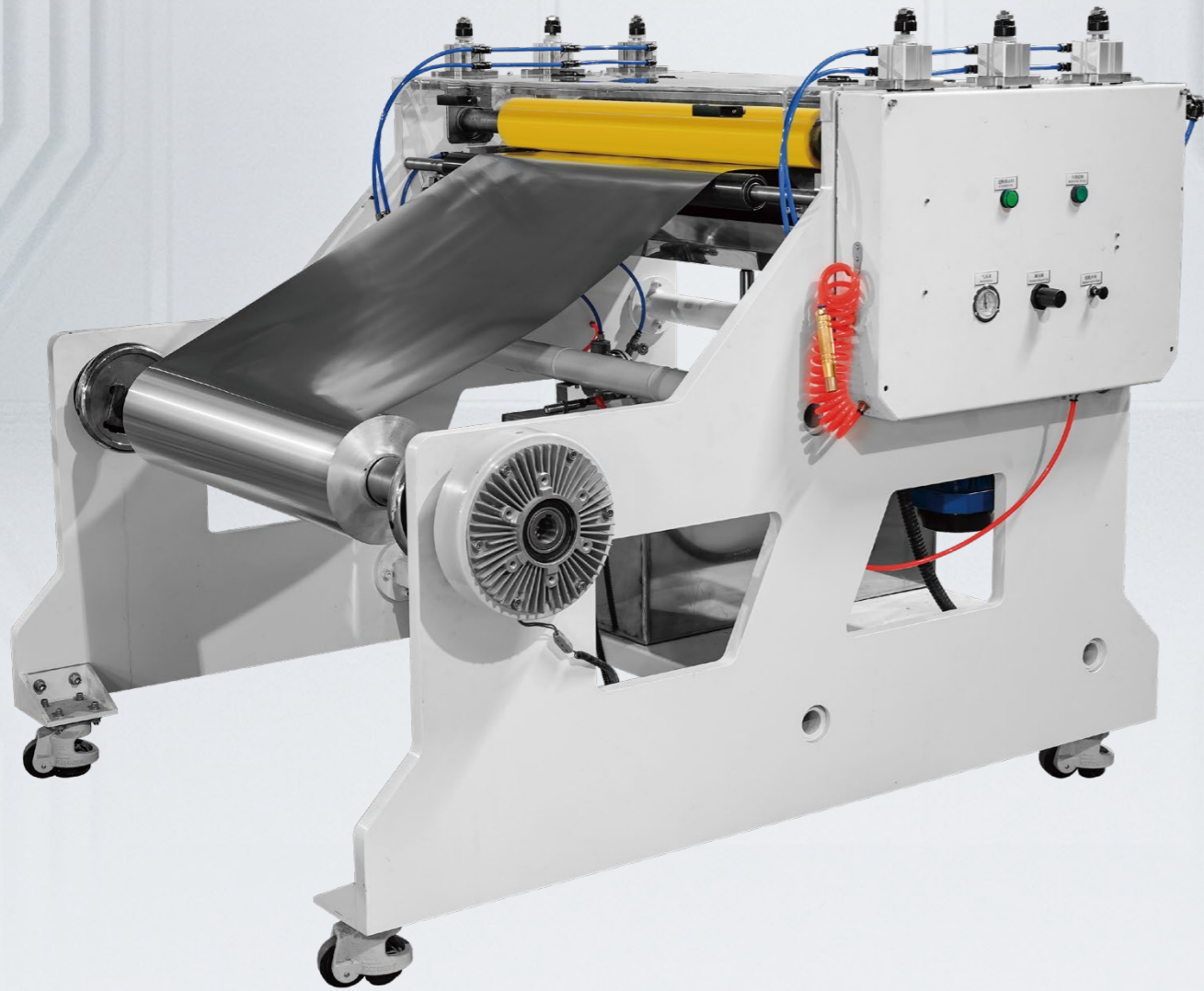

EQUIPMENT CHARACTERISTICS 设备特点



表面喷油系统
Surface oil spraying system

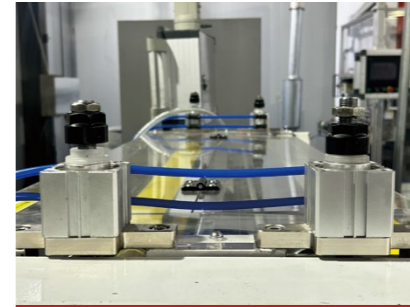

气动锁辊
Pneumatic lock shaft

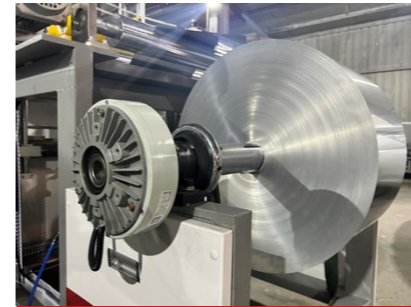

放料张力控制系统
Unwinding tension control system

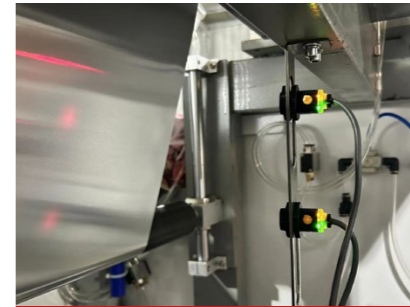

缺料自动报警
Lack of material detection

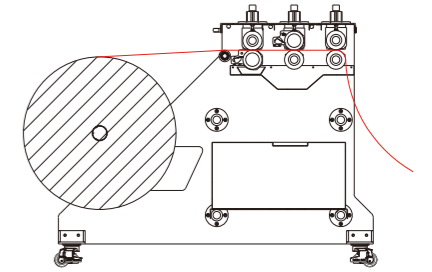
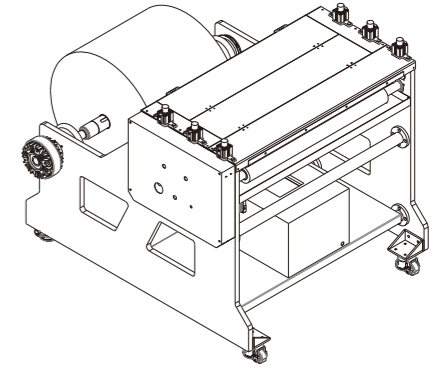

MAIN TECHNICAL PARAMETERS 主要技术参数

型号	Model	ZBF-S
适用铝箔类型	Applicable Aluminum Foil Types	Non-Lubricated and Lubricated Foil Material
适用容器类型	Applicable Container Type	Wrinkle Wall Container and Smooth Wall Container 有皱和无皱容器
适用冲压油类型	Applicable Stamping Oil Type	Thick Oil, Fresh Point No Limited
油箱布局	Tank Layout	Closed Oil Tank under Feeder 封闭式油箱
涂油方式	Oil Application Method	Foil Roller Coating 涂层辊
油补给方式	Oil Replenishment Method	Automatic Refill 自动注油
耗油量	Oil Consumption	300-500mg/sqm
冲压油污染	Stamping Oil Contamination	Auto Filtrate and Cycle Clean 自动过滤循环清洁系统
送料辊数量	Number Of Feed Rollers	6sets

ZBWP-30T/60T

Wastage packaging system

铝箔废料处理系统

AS-900/1300/1500

Aluminum Foil Container Stacker

铝箔容器堆垛机

▼ ZBWP-30T



▼ ZBWP-60T



MAIN TECHNICAL PARAMETERS 主要技术参数

型号	Model	ZBWP-30T	ZBWP-60T
废料入口数	Number Of Waste Inlets	两条生产线共两个	10条生产线10个
压缩力	Compression Force	30吨	60吨
主电机功率	Main Motor Power	5.5kw	15kw
打包尺寸	Packing Size	400x400x100~300mm	600x600x100~700mm
加料口尺寸	Size Of Feeding Port	300x300mm	500x500mm
控制方式	Control Mode	自动/半自动	自动/半自动
液压缸数量	Number Of Hydraulic Cylinders	三个单元	三个单元
出包方式	Bale Discharge Mode	自动推送	自动推送
分离器尺寸	Separator Size	600mm	1200mm
设备尺寸	Equipment Size	1500x1200x2500mm	5350x1000x1500mm
设备重量	Equipment Weight	1500KGS	4000KGS

MAIN TECHNICAL PARAMETERS 主要技术参数

型号	Model	AS-900	AS-1300	AS-1500
航道数量	Lane Quantity	1-4lanes	2-6lanes	3-7lanes
输送带尺寸	Belt Dimension	L2000xW900	L2000x1300mm	L2000x1500mm
堆垛机平台高度	Belt Height	1050-1300mm	1050-1300mm	1050-1300mm
最小适用尺寸	Min. Container Size	100x100mm	100x100mm	100x100mm
产品堆垛尺寸	Products Stacking Size	One lane: L500xW800xH350mm Two lane: L500xW400xH350mm Three lane: L500xW250xH350mm Four lane: L500xW190xH350mm	Three lane: L600xW350xH350mm Four lane: L600xW250xH350mm Five lane: L600xW210xH350mm Six lane: L600xW170xH350mm	Four lane: L600xW300xH350mm Five lane: L600xW240xH350mm Six lane: L600xW200xH350mm Seven lane:L600xW170xH350mm
升降系统	Lifting System	Servo Cylinder	Servo Cylinder	Servo Cylinder
检测和计数	Detect &Counting	Sensor and Optical Fiber	Sensor and Optical Fiber	Sensor and optical fiber
主电机	Main Motor	1.2KW	1.5KW	2KW
设备尺寸	Machine Size	2500x1200x1500mm	2500x1500x1500mm	2500x1800x1500mm
设备重量	Machine Weight	1500KG	1800KG	2000KG

About Molds

关于模具

Perfect quality

完美的品质

01

采用加厚特制优质模具钢,严格按照欧洲模具钢材标准,符合食品免洗容器生产卫生需求。

It adopts thickened special high-quality die steel, strictly in accordance with European die steel standards, in line with the hygienic requirements of the production of food non-washing containers.

02

核心部件均由自有CNC和中慢丝线切割机加工,热处理及铝件加表面硬度处理更耐磨。

Core components are self-CNC and slow wire cutting machine processing, heat treatment and aluminum surface hardness treatment more wear-resistant.

03

提供2年免费保修、项目后续签服务,拥有基本英语沟通能力,完善的使用说明书和售后视频。

Provide 2-year warranty, project follow-up service, basic English communication skills, improve the use of the manual and after-sales video.

04

对不同合金的铝箔材料具有更好的适用性,适用7大类型。

It has better applicability to aluminum foil materials of different alloys, suitable for 7 types.

05

通过优化设计产品结构和剪口排列工艺,达到更低废边率的目标,模具废边率较市场同类型降低2-5%。

By optimizing the product structure and cutting arrangement process, the lower scrap edge rate was achieved, and the scrap edge rate was reduced by 2-5% compared with the same type of die in the market.

06

完善的中英文使用说明,轻松掌握日常维护,所有模具图纸都精准存档,方便加工替换一模一样的新配件。

Perfect Chinese and English instructions, easy to master the daily maintenance, all die drawings are accurately filed, easy to replace the same new accessories.

Complete Customization Process

完善的定制流程

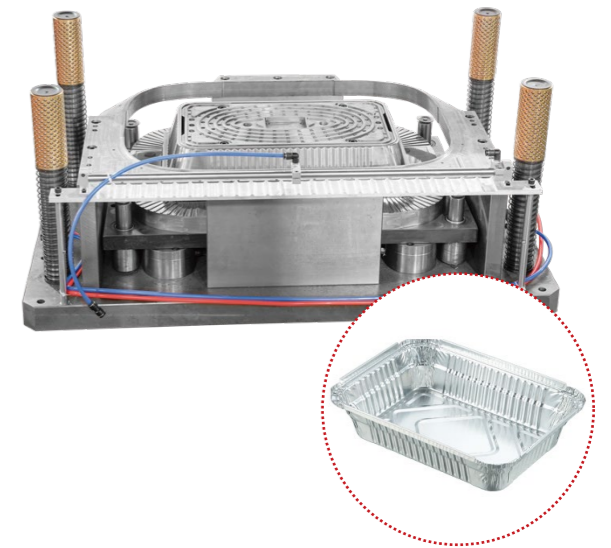
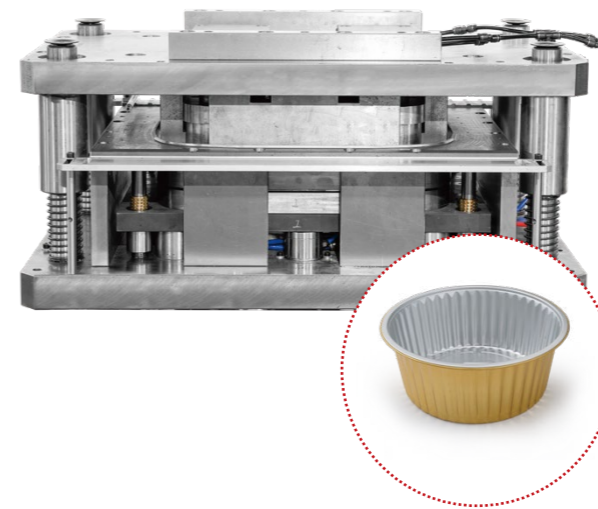
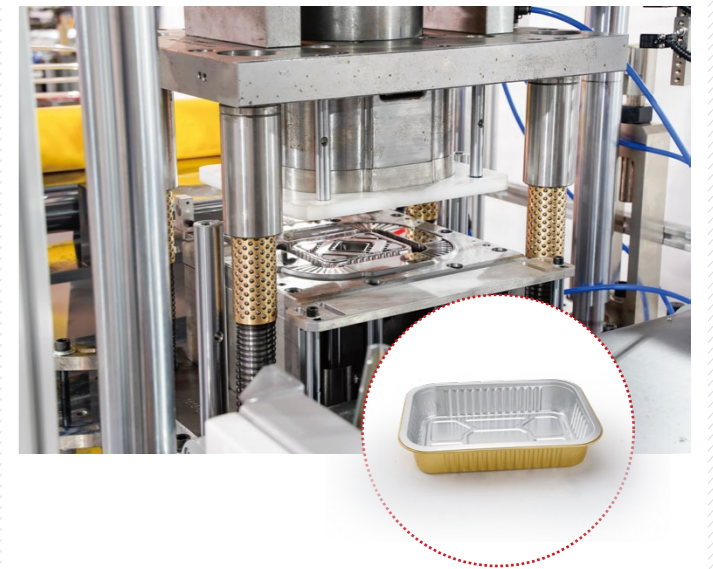
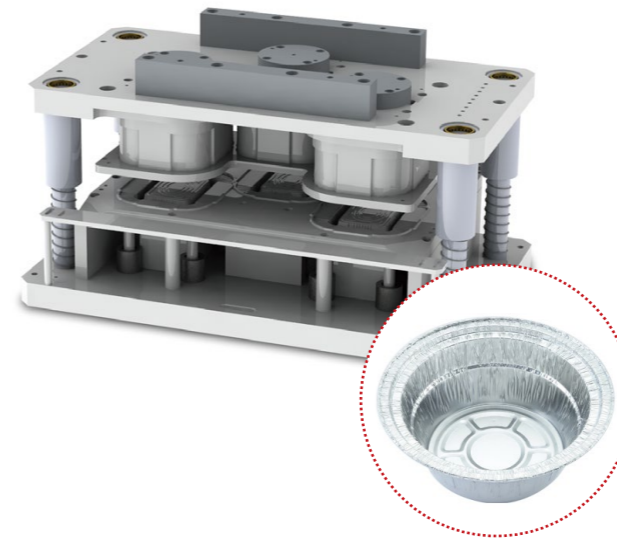

PY HS

Roll Die Cutting And Stripping Machine

卷筒平压平模切清边机

EQUIPMENT CHARACTERISTICS 设备特点

PYHS系列卷筒平压平模切清边机是在标准模切机的基础上增加清废单元，实现对纸杯片、纸盘、纸盒等产品进行模切、压痕、压纹、清废取品等加工任务。

PY HS series roll die cutting and stripping machine is added stripping unit based on the PY series It is an ideal and professional machine in die cutting, creasing, embossing and four sides stripping for paper cup fan, paper plate, carton box, etc.



选配OPTIONAL:

无轴放料
SHAFTLESS UNWINDING



色标定位
COLOR SENSOR TRACKING



伺服传送
SERVO DRIVING



顶针式清废
PIN STRIPPING



远程监控
REMOTE MONITOR



自动张力控制
AUTO TENSION CONTROLLER

MAIN TECHNICAL PARAMETERS 主要技术参数

型号	Model	PY-950HS	PY-1200HS	PY-1300HS
模切速度	Capacity	100-180次/分钟 times/min	100-180次/分钟 times/min	100-180次/分钟 times/min
最大模切面积	Max Cutting Size	950x540mm (选配Option 950x640mm)	1200x640mm	1300x750mm
模切精度	Precision	±0.20mm	±0.20mm	±0.20mm
清废尺寸	Stripping Size	950x510mm can customized for the max size 可根据产品最大尺寸来定做	1200x510mm	1300x510mm
送纸宽度	Paper Convey Width	950-400mm	1200-400mm	1300-400mm
最大放卷直径	Max Roll Paper Diameter	1600mm(选配无轴放卷: shaftless unwinding:1600mm)		
适用材料	Suitable Material	100-600克/平方米单面或双面PE淋膜纸张 100-600g/m ² white cardboard, PE coated paper, Kraft paper.etc As long as your material can be roll, the machine can die cut.		
最大模切压力	Maximum Pressure	350T	350T	350T
总功率	Total Power	20KW	22KW	23KW
电源	Power Source	380V 50HZ (other voltage can be customized) 可定制变压器		
工作压力	Working Air Source	0.2m ³ /min, 0.5-0.7Mpa		
总重量	Weight	11.5T	13T	15T
包装尺寸	Overall Dimension	10500x2500x1925mm	10700x2900x1925mm	11000x2700x1925mm
其他规格可按照需求定做 other size can be customized				

PY

Roll Die Cutting Machine

卷筒平压平模切机



选配OPTIONAL:
无轴放料
SHAFTLESS UNWINDING



远程监控
REMOTE MONITOR

伺服直联传动
CONNECTED DIREATLY

自动张力控制
AUTO TENSION CONTROLLER

外置油路循环系统
EXTERNAL LUBRICATION

色标定位
COLOR SENSOR TRACKING

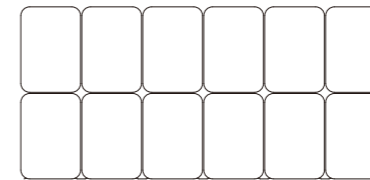
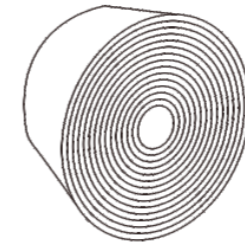

EQUIPMENT CHARACTERISTICS 设备特点

PY系列全自动高速卷筒平压平模切机是模切、压痕、压纹淋膜纸、白卡纸、牛皮纸等各种纸张的专业设备，适用于纸杯、纸盒、药盒、手提袋等所有纸类包装产品。

PY series high speed roll die-cutting machine is an ideal and professional machine in die-cutting ,creasing , embossing and full-stripping various PEcoated paper, normal paper , corrugatingpaperand plastic material.

MAIN TECHNICAL PARAMETERS 主要技术参数

型号	Model	PY-950	PY-1200	PY-1300	PY-1450
模切速度	Capacity	150-260次/分钟 times/min (mechanical speed max 260 times)	150-240次/分钟 times/min (mechanical speed max 260 times)	130-210次/分钟 times/min (mechanical speed max 260 times)	100-210次/分钟 times/min (mechanical speed max 260 times)
最大模切面积	Max Cutting Size	950x540mm PY-950P:950x640mm PY-950H:950x540mm加重型 heavy model	1200x640mm	1300x750mm	1450x750mm
模切精度	Precision	±0.20mm	±0.20mm	±0.20mm	±0.20mm
送纸宽度	Paper Convey Width	950-300mm	1200-300mm	1300-300mm	1450-300mm
最大放卷直径	Max Roll Paper Diameter	1600mm(选配无轴放卷: shaftless unwinding:1600mm)			
适用材料	Suitable Material	100-800克/平方米单面或双面PE淋膜纸张 100-800g/m ² white cardboard, PE coated paper, Kraft paper.etc			
最大模切压力	Maximum Pressure	350T	350T	350T	350T
总功率	Total Power	13.5KW	17KW	17KW	18KW
电源	Power Source	380V 50HZ (other voltage can be customized) 可定制变压器			
工作压力	Working Air Source	0.2m ³ /min, 0.5-0.7Mpa			
总重量	Weight	7000KGS	9000KGS	10500KGS	13000KGS
包装尺寸	Overall Demension	4500x2100x2100mm	4600x2300x2100mm	4700x2300x2100mm	4700x2300x2100mm

其他规格可按照需求定做 other size can be customized

JTCQ-D900/1200

High Speed Roll Punching Machine(Four-link Driving)
高速卷筒冲切机(四连杆)



EQUIPMENT CHARACTERISTICS 设备特点

JTCQ-D高速卷筒冲切机是专门用于卷筒纸杯、纸盘、杯盖等模切，可以根据需要通过更换模具来完成不同尺寸的纸片冲切及清废，是柔版印刷机的理想配套模切机。

JTCQ-D Roll automatic punching machine is a good choice for punching papercupfan, paper lid with different sizes by changing molds. High speed and good performance with stripping. It is a good partner for the flexoprinting machine.

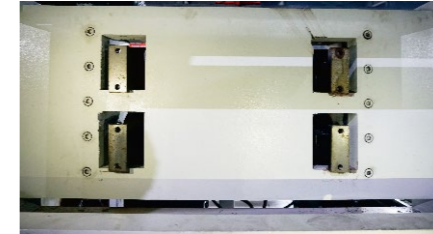

新型四连杆传动
NEW DRIVING SYSTEM

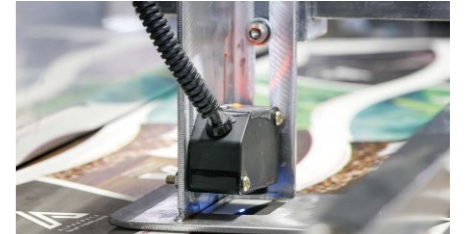

色标定位
COLOR SENSOR TRACKING



高精度钢模
HIGH QUALITY METAL MOLD



自动张力控制
AUTO TENSION CONTROLLER

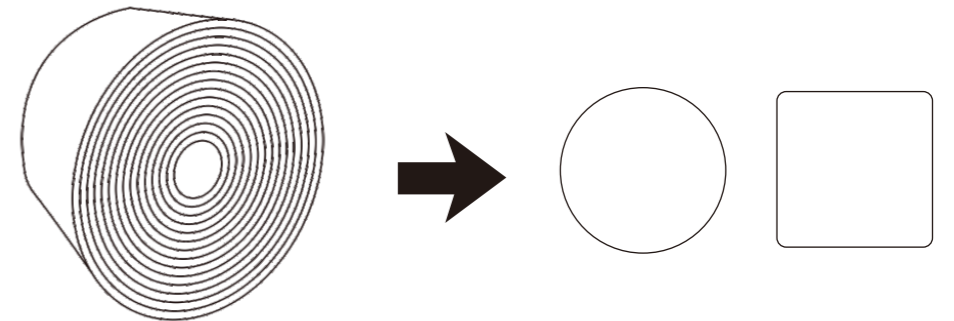

MAIN TECHNICAL PARAMETERS 主要技术参数

型号	Model	JTCQ-D900	JTCQ-D1200
模切速度	Capacity	300-400次/分钟 times/min (mechanical speed max 400 times)	
模切精度	Precision	±0.20mm	±0.20mm
最大送纸宽度	Max Paper Convey Width	900-300mm	1200-300mm
最大模切面积	Maximum Cutting Size	900x380mm	1200x380mm
最大放卷直径	Max Roll Paper Dimeter	1600mm(选配无轴放卷: shaftless unwinding:1600mm)	
总功率	Total Power	7KW	7KW
电源	Power Source	380V 50HZ (other voltage can be customized) 可定制变压器	
工作压力	Working Air Source	0.2m³/min, 0.5-0.7Mpa	
适用材料	Suitable Material	100-450g/m² PE coated paper, white cardboard paper 淋膜纸、白卡纸等	
总重量	Weight	3580KGS	5050KGS
包装尺寸	Overall Dimension	3700x2100x1850mm	3700x2300x1850mm

其他规格可按照需求定做 other size can be customized

DEVELOP PRODUCTS THAT MEET CUSTOMER NEEDS

STRENGTHEN QUALITY COMPETITIVENESS

开发符合客户需求的产品

强化质量竞争力



Stable Equipment
性能稳定的设备



Superb production technology
精湛的
生产工艺



Tailor-made overall solution
量身定制的
整体解决方案



无皱容器

SMOOTH WALL CONTAINER



圆形铝箔餐盒

Round

型号 No.1	图片展示 picture	容器参数 Parameters	容器参数 Parameters
ZY052-25S		<ul style="list-style-type: none"> 52x52mm 2.04x2.04in 44x44mm 1.73x1.73in 39x39mm 1.53x1.53in 20mm 0.78in 25ml 0.8fl.oz 	Case Pack 1000pcs Case Cube 0.013m ³ 0.459cu ft 40HQ Cases 5153ctn
ZY054-40S		<ul style="list-style-type: none"> 54x54mm 2.12x2.12in 45x45mm 1.77x1.77in 39x39mm 1.53x1.53in 30mm 1.18in 40ml 1.4fl.oz 	Case Pack 1000pcs Case Cube 0.026m ³ 0.918cu ft 40HQ Cases 2576ctn
ZY058-48S		<ul style="list-style-type: none"> 58x58mm 2.28x2.28in 50x50mm 1.96x1.96in 43x43mm 1.69x1.69in 25mm 0.98in 48ml 1.6fl.oz 	Case Pack 1000pcs Case Cube 0.032m ³ 1.130cu ft 40HQ Cases 2093ctn

圆形铝箔餐盒

Round

型号 No.1	图片展示 picture	容器参数 Parameters	容器参数 Parameters
ZY059-60S		<ul style="list-style-type: none"> 59x59mm 2.32x2.32in 50x50mm 1.96x1.96in 41x41mm 1.61x1.61in 38mm 1.49in 60ml 2.1fl.oz 	Case Pack 1000pcs Case Cube 0.033m ³ 1.165cu ft 40HQ Cases 2030ctn
ZY084-100S		<ul style="list-style-type: none"> 84x84mm 4.30x4.30in 75x75mm 2.95x2.95in 62x62mm 2.44x2.44in 28mm 1.10in 100ml 3.5fl.oz 	Case Pack 1000pcs Case Cube 0.017m ³ 0.600cu ft 40HQ Cases 3940ctn
ZY141-275S		<ul style="list-style-type: none"> 141x141mm 5.55x5.55in 128x128mm 5.03x5.03in 114x114mm 5.55x5.55in 22mm 0.86in 275ml 9.6fl.oz 	Case Pack 1000pcs Case Cube 0.046m ³ 1.624cu ft 40HQ Cases 1456ctn
ZY120-360S		<ul style="list-style-type: none"> 120x120mm 4.72x4.72in 106x106mm 4.17x4.17in 50x50mm 1.96x1.96in 52mm 2.04in 360ml 12.6fl.oz 	Case Pack 1000pcs Case Cube 0.032m ³ 1.130cu ft 40HQ Cases 2093ctn
ZY144-630S		<ul style="list-style-type: none"> 144x144mm 5.66x5.66in 130x130mm 5.11x5.11in 110x110mm 4.33x4.33in 60mm 2.36in 630ml 22.1fl.oz 	Case Pack 1000pcs Case Cube 0.047m ³ 1.660cu ft 40HQ Cases 1425ctn
ZY180-1000S		<ul style="list-style-type: none"> 180x180mm 7.09x7.09in 163x163mm 6.42x6.42in 100x100mm 3.94x3.94in 50mm 1.97in 1000ml 35.2fl.oz 	Case Pack 1000pcs Case Cube 0.07m ³ 2.465cu ft 40HQ Cases 957ctn
ZY180-1130S		<ul style="list-style-type: none"> 180x180mm 7.08x7.08in 165x165mm 6.49x6.49in 146x146mm 5.74x5.74in 60mm 3.14in 1130ml 39.7fl.oz 	Case Pack 1000pcs Case Cube 0.07m ³ 2.465cu ft 40HQ Cases 957ctn

圆形铝箔餐盒

Round

型号 No.1	图片展示 picture	容器参数 Parameters	容器参数 Parameters
ZY180-1235S		<ul style="list-style-type: none"> 180x180mm 7.08x7.08in 168x168mm 6.61x6.61in 145x145mm 5.70x5.70in 68mm 2.67in 1235ml 43.47fl.oz 	Case Pack 1000pcs Case Cube 0.082m ³ 2.896cu ft 40HQ Cases 817ctn
ZY180-1370S		<ul style="list-style-type: none"> 180x180mm 7.08x7.08in 165x165mm 6.49x6.49in 140x140mm 5.51x5.51in 80mm 3.14in 1370ml 48.2fl.oz 	Case Pack 1000pcs Case Cube 0.082m ³ 2.408cu ft 40HQ Cases 817ctn
ZY250-2000S		<ul style="list-style-type: none"> 250x250mm 9.84x9.84in 230x230mm 9.05x9.05in 210x210mm 8.26x8.26in 55mm 2.16in 2000ml 70.3fl.oz 	Case Pack 500pcs Case Cube 0.074m ³ 2.613cu ft 40HQ Cases 905ctn
ZY250-2500S		<ul style="list-style-type: none"> 250x250mm 9.84x9.84in 230x230mm 9.05x9.05in 210x210mm 8.26x8.26in 68mm 2.67in 2500ml 87.9fl.oz 	Case Pack 500pcs Case Cube 0.076m ³ 2.684cu ft 40HQ Cases 881ctn
ZY250-3000S		<ul style="list-style-type: none"> 250x250mm 9.84x9.84in 230x230mm 9.05x9.05in 200x200mm 7.87x7.87in 85mm 3.34in 3000ml 105.5fl.oz 	Case Pack 500pcs Case Cube 0.077m ³ 2.719cu ft 40HQ Cases 870ctn
ZY250-3500S		<ul style="list-style-type: none"> 250x250mm 9.84x9.84in 230x230mm 9.05x9.05in 206x206mm 8.11x8.11in 100mm 3.93in 3500ml 123.1fl.oz 	Case Pack 500pcs Case Cube 0.081m ³ 2.860cu ft 40HQ Cases 827ctn
ZY280-5000S		<ul style="list-style-type: none"> 280x280mm 5x5in 230x230mm in 206x206mm 13.7x13.7in 100mm 1.97in 5000ml 8.8fl.oz 	Case Pack 1000pcs Case Cube 0.081m ³ 2.860cu ft 40HQ Cases 827ctn

矩形铝箔餐盒

Rectangles

型号 No.1	图片展示 picture	容器参数 Parameters	容器参数 Parameters
ZF0705-50S		<ul style="list-style-type: none"> 72x54mm 2.83x2.12in 62x44mm 2.44x1.73in 56x38mm 2.20x1.49in 19mm 0.74in 50ml 1.75fl.oz 	Case Pack 2000pcs Case Cube 0.019m ³ 0.671cu ft 40HQ Cases 3526ctn
ZF9292-100S		<ul style="list-style-type: none"> 92x92mm 3.62x3.62in 80x80mm 3.14x3.14in 73x73mm 2.87x2.87in 24mm 0.94in 100ml 3.5fl.oz 	Case Pack 1000pcs Case Cube 0.022m ³ 0.777cu ft 40HQ Cases 3045ctn
ZF1606-200S		<ul style="list-style-type: none"> 167x67mm 6.57x2.63in 156x58mm 6.14x2.28in 146x47mm 5.74x1.85in 30mm 1.18in 200ml 7.0fl.oz 	Case Pack 1000pcs Case Cube 0.029m ³ 1.024cu ft 40HQ Cases 2310ctn
ZF2311-500S		<ul style="list-style-type: none"> 229x113mm 9.01x4.44in 217x101mm 8.54x3.97in 205x90mm 8.07x3.54in 32mm 1.25in 500ml 17.5fl.oz 	Case Pack 500pcs Case Cube 0.033m ³ 1.165cu ft 40HQ Cases 2030ctn
ZF1913-550S		<ul style="list-style-type: none"> 186x128mm 7.32x5.03in 177x115mm 6.96x4.52in 150x94mm 5.90x3.70in 35mm 1.37in 550ml 19.3fl.oz 	Case Pack 500pcs Case Cube 0.030m ³ 1.059cu ft 40HQ Cases 2233ctn
ZF1913-1025S		<ul style="list-style-type: none"> 187x129mm 7.36x5.07in 175x117mm 6.88x4.60in 150x94mm 5.90x3.70in 65mm 2.55in 1025ml 36.0fl.oz 	Case Pack 500pcs Case Cube 0.031m ³ 1.095cu ft 40HQ Cases 2161ctn
ZF2215-1200S		<ul style="list-style-type: none"> 220x151mm 8.66x5.94in 203x131mm 7.99x5.15in 189x118mm 7.44x4.64in 45mm 1.77in 1200ml 42.2fl.oz 	Case Pack 500pcs Case Cube 0.042m ³ 1.483cu ft 40HQ Cases 1592ctn

矩形铝箔餐盒

Rectangles

型号 No.1	图片展示 picture	容器参数 Parameters	容器参数 Parameters
ZF1611-320S		<ul style="list-style-type: none"> 161x112mm 6.37x4.33in 141x91mm 5.90x3.81in 140x88mm 5.51x3.46in 30mm 1.18in 320ml 11.2fl.oz 	Case Pack 1000pcs Case Cube 0.044m ³ 1.554cu ft 40HQ Cases 1522ctn
ZF1611-475S		<ul style="list-style-type: none"> 161x112mm 6.37x4.33in 137x88mm 5.90x3.81in 140x88mm 5.51x3.46in 40mm 1.18in 475ml 11.2fl.oz 	Case Pack 1000pcs Case Cube 0.044m ³ 1.554cu ft 40HQ Cases 1522ctn
ZF1611-680S		<ul style="list-style-type: none"> 161x112mm 6.49x2.59in 131x82mm 6.06x2.16in 146x47mm 5.75x1.85in 55mm 1.18in 680ml 7.87fl.oz 	Case Pack 1000pcs Case Cube 0.022m ³ 0.781cu ft 40HQ Cases 5400ctn
ZF1612-425S		<ul style="list-style-type: none"> 162x118mm 145x101mm 144x100mm 32mm 425ml 	Case Pack 100pcs Case Cube 0.008m ³ 0.267cu ft 40HQ Cases 9100ctn
ZF2116-740S		<ul style="list-style-type: none"> 208x156mm 191x139mm 175x126mm 33mm 740ml 	Case Pack 100pcs Case Cube 0.011m ³ 0.387cu ft 40HQ Cases 5850ctn
ZF2520-1340S		<ul style="list-style-type: none"> 247x194mm 229x176mm 211x160mm 40mm 1340ml 	Case Pack 100pcs Case Cube 0.016m ³ 0.574cu ft 40HQ Cases 4180ctn
ZF2822-1790S		<ul style="list-style-type: none"> 284x220mm 266x202mm 247x183mm 40mm 1790ml 	Case Pack 50pcs Case Cube 0.013m ³ 0.442cu ft 40HQ Cases 5280ctn

矩形铝箔餐盒

Rectangles

型号 No.1	图片展示 picture	容器参数 Parameters	容器参数 Parameters
ZF2919-2040S		<ul style="list-style-type: none"> 293x192mm 2.04x2.04in 275x174mm 1.73x1.73in 258x157mm 1.53x1.53in 50mm 0.78in 2040ml 0.8fl.oz 	Case Pack 200pcs Case Cube 0.031m ³ 1.117cu ft 40HQ Cases 1920ctn
ZF1715-720S		<ul style="list-style-type: none"> 167x152mm 6.57x5.98in 133x133mm 5.24x5.24in 118x118mm 4.65x4.65in 52mm 2.05in 720ml 28.35fl.oz 	Case Pack 500pcs Case Cube 0.034m ³ 1.209cu ft 40HQ Cases 1904ctn
ZF1313-350S		<ul style="list-style-type: none"> 125x125mm 4.92x4.92in 110x110mm 4.33x4.33in 100x100mm 13.7x13.7in 50mm 1.97in 350ml 12.32fl.oz 	Case Pack 1000pcs Case Cube 0.042m ³ 1.475cu ft 40HQ Cases 1610ctn
ZF1414-400S		<ul style="list-style-type: none"> 140x140mm 5.51x5.51in 124x124mm 4.88x4.88in 110x110mm 4.33x4.33in 47mm 1.85in 400ml 14.0fl.oz 	Case Pack 1000pcs Case Cube 0.052m ³ 1.821cu ft 40HQ Cases 1368ctn

心形铝箔餐盒

Heart shape

型号 No.1	图片展示 picture	容器参数 Parameters	容器参数 Parameters
ZX52-25S		<ul style="list-style-type: none"> 52x52mm 2.04x2.04in 44x44mm 1.73x1.73in 39x39mm 1.53x1.53in 20mm 0.78in 25ml 0.8fl.oz 	Case Pack 2000pcs Case Cube 0.01m ³ 0.553cu ft 40HQ Cases 6720ctn
ZX80-100S		<ul style="list-style-type: none"> 86x80mm 7.20x7.20in 69x62mm 6.61x6.61in 145x145mm 5.70x5.70in 29mm 2.67in 100ml 43.47fl.oz 	Case Pack 1000pcs Case Cube 0.016m ³ 0.553cu ft 40HQ Cases 4312ctn

有皱容器 WRINKLE WALL CONTAINER



圆形容器

Round

型号 No.1	图片展示 picture	容器参数 Parameters	容器参数 Parameters
ZY79-150W		<ul style="list-style-type: none"> 79x79mm 3.11x3.11in 68x68mm 2.68x2.68in 52x52mm 2.05x2.05in 57mm 2.24in 150ml 5.91fl.oz 	Case Pack 1000pcs Case Cube 0.0135m ³ 0.479cu ft 40HQ Cases 5040ctn
ZY90-360W		<ul style="list-style-type: none"> 90x90mm 3.54x3.54in 75x75mm 2.95x2.95in 55x55mm 2.16x2.16in 45mm 1.77in 360ml 12.6fl.oz 	Case Pack 1000pcs Case Cube 0.021m ³ 0.742cu ft 40HQ Cases 3196ctn
ZY100-360W		<ul style="list-style-type: none"> 100x100mm 3.93x3.93in 93x93mm 3.66x3.66in 50x50mm 1.96x1.96in 40mm 1.57in 360ml 12.6fl.oz 	Case Pack 1000pcs Case Cube 0.023m ³ 0.812cu ft 40HQ Cases 2913ctn
ZY108-360W		<ul style="list-style-type: none"> 108x108mm 4.25x4.25in 95x95mm 3.74x3.74in 90x90mm 3.54x3.54in 24mm 0.94in 360ml 12.6fl.oz 	Case Pack 1000pcs Case Cube 0.023m ³ 0.812cu ft 40HQ Cases 2913ctn

圆形铝箔餐盒

Round

型号 No.1	图片展示 picture	容器参数 Parameters	容器参数 Parameters
ZY120-270W		<ul style="list-style-type: none"> 120x120mm 4.72x4.72in 105x105mm 4.13x4.13in 85x85mm 3.35x3.35in 41mm 1.61in 270ml 9.13fl.oz 	Case Pack 1000pcs Case Cube 0.036m ³ 1.266cu ft 40HQ Cases 1869ctn
ZY147-800W		<ul style="list-style-type: none"> 147x147mm 5.79x5.79in 133x133mm 5.24x5.24in 115x115mm 4.53x4.53in 40mm 1.57in 800ml 28.16fl.oz 	Case Pack 1000pcs Case Cube 0.066m ³ 2.330cu ft 40HQ Cases 980ctn
ZY170-360W		<ul style="list-style-type: none"> 170x170mm 6.69x6.69in 150x150mm 5.90x5.90in 130x130mm 5.11x5.11in 43mm 1.69in 360ml 12.6fl.oz 	Case Pack 1000pcs Case Cube 0.052m ³ 1.836cu ft 40HQ Cases 1288ctn
ZY181-750W		<ul style="list-style-type: none"> 181x181mm 7.13x7.13in 147x147mm 5.79x5.79in 111x111mm 4.37x4.37in 65mm 2.56in 750ml 26.4fl.oz 	Case Pack 1000pcs Case Cube 0.092m ³ 3.239cu ft 40HQ Cases 730ctn
ZY183-630W		<ul style="list-style-type: none"> 183x183mm 7.2x7.2in 166x166mm 6.54x6.54in 141x141mm 5.55x5.55in 43mm 1.69in 630ml 22.18fl.oz 	Case Pack 500pcs Case Cube 0.044m ³ 1.538cu ft 40HQ Cases 1596ctn
ZY183-770W		<ul style="list-style-type: none"> 183x183mm 7.2x7.2in 166x166mm 6.54x6.54in 140x140mm 5.51x5.51in 50mm 1.97in 770ml 27.1fl.oz 	Case Pack 500pcs Case Cube 0.05m ³ 1.759cu ft 40HQ Cases 1345ctn
ZY215-360W		<ul style="list-style-type: none"> 215x215mm 8.46x8.46in 200x200mm 7.87x7.87in 176x176mm 6.92x6.92in 46mm 1.81in 360ml 12.6fl.oz 	Case Pack 500pcs Case Cube 0.043m ³ 1.518cu ft 40HQ Cases 1558ctn

圆形铝箔餐盒

Round

型号 No.1	图片展示 picture	容器参数 Parameters	容器参数 Parameters
ZY218-920W		<ul style="list-style-type: none"> 218x218mm 8.58x8.58in 198x198mm 7.8x7.8in 179x179mm 7.05x7.05in 45mm 1.77in 920ml 32.38fl.oz 	Case Pack 500pcs Case Cube 0.053m ³ 1.877cu ft 40HQ Cases 1080ctn
ZY235-360W		<ul style="list-style-type: none"> 235x235mm 9.25x9.25in 210x210mm 8.26x8.26in 200x200mm 7.87x7.87in 50mm 1.96in 360ml 12.6fl.oz 	Case Pack 500pcs Case Cube 0.052m ³ 1.836cu ft 40HQ Cases 1288ctn
ZY2118-1150W		<ul style="list-style-type: none"> 209x179mm 8.23x7.05in 158x158mm 6.22x6.22in 135x135mm 5.31x5.31in 79mm 3.11in 1150ml 45.28fl.oz 	Case Pack 500pcs Case Cube 0.06m ³ 2.219cu ft 40HQ Cases 1120ctn
ZY2522-2200W		<ul style="list-style-type: none"> 253x221mm 9.96x8.70in 194x194mm 7.63x7.63in 164x164mm 6.45x6.45in 98mm 3.85in 2200ml 86.61fl.oz 	Case Pack 500pcs Case Cube 0.16m ³ 4.098cu ft 40HQ Cases 600ctn
ZY3026-4000W		<ul style="list-style-type: none"> 291x263mm 11.46x10.35in 237x237mm 9.33x9.33in 204x204mm 8.03x8.03in 117mm 4.61in 4000ml 157.48fl.oz 	Case Pack 500pcs Case Cube 0.18m ³ 6.36cu ft 40HQ Cases 304ctn
ZY3430-5690W		<ul style="list-style-type: none"> 336x305mm 13.22x12.00in 276x276mm 10.86x10.86in 243x243mm 9.56x9.56in 120mm 4.72in 5690ml 224.02fl.oz 	Case Pack 200pcs Case Cube 0.10m ³ 3.66cu ft 40HQ Cases 608ctn
ZY3935-8080W		<ul style="list-style-type: none"> 392x354mm 15.43x13.94in 330x330mm 12.99x12.99in 290x290mm 11.42x11.42in 117mm 4.61in 8080ml 318.11fl.oz 	Case Pack 200pcs Case Cube 0.14m ³ 4.864cu ft 40HQ Cases 450ctn

矩形铝箔餐盒

Rectangles

型号 No.1	图片展示 picture	容器参数 Parameters	容器参数 Parameters
ZF1108-150W		<ul style="list-style-type: none"> 112x84mm 4.41x3.31in 100x72mm 3.94x2.83in 83x54mm 3.27x2.13in 35mm 1.38in 150ml 5.28fl.oz 	Case Pack 1000pcs Case Cube 0.021m ³ 0.749cu ft 40HQ Cases 3159ctn
ZF1310-250W		<ul style="list-style-type: none"> 126x100mm 4.96x3.94in 112x86mm 4.41x3.39in 92x66mm 3.62x2.60in 43mm 1.69in 250ml 8.8fl.oz 	Case Pack 1000pcs Case Cube 0.027m ³ 0.945cu ft 40HQ Cases 2504ctn
ZF1512-420W		<ul style="list-style-type: none"> 145x120mm 5.71x4.72in 131x106mm 5.16x4.17in 95x70mm 3.74x2.76in 46mm 1.81in 420ml 14.78fl.oz 	Case Pack 1000pcs Case Cube 0.039m ³ 1.377cu ft 40HQ Cases 1718ctn
ZF1616-530W		<ul style="list-style-type: none"> 158x158mm 6.22x6.22in 140x140mm 5.51x5.51in 118x118mm 4.65x4.65in 42mm 1.65in 530ml 18.66fl.oz 	Case Pack 1000pcs Case Cube 0.057m ³ 2.033cu ft 40HQ Cases 1152ctn
ZF1711-350W		<ul style="list-style-type: none"> 174x112mm 6.85x4.41in 158x99mm 6.22x3.90in 137x78mm 5.39x3.07in 38mm 1.5in 350ml 12.32fl.oz 	Case Pack 1000pcs Case Cube 0.052m ³ 1.831cu ft 40HQ Cases 1292ctn
ZF2515-1600W		<ul style="list-style-type: none"> 250x150mm 9.84x5.91in 230x130mm 9.06x5.12in 204x105mm 8.03x4.13in 70mm 2.76in 1600ml 56.32fl.oz 	Case Pack 500pcs Case Cube 0.086m ³ 3.030cu ft 40HQ Cases 781ctn
ZF3121-1950W		<ul style="list-style-type: none"> 314x213mm 12.36x8.39in 294x194mm 11.57x7.64in 270x170mm 10.63x6.69in 50mm 1.97in 1950ml 68.64fl.oz 	Case Pack 200pcs Case Cube 0.095m ³ 3.356cu ft 40HQ Cases 705ctn

矩形铝箔餐盒

Rectangles

型号 No.1	图片展示 picture	容器参数 Parameters	容器参数 Parameters
ZF1310-220W		<ul style="list-style-type: none"> 126x100mm 4.96x3.94in 112x86mm 4.41x3.39in 92x66mm 3.62x2.60in 33mm 1.3in 220ml 7.74fl.oz 	Case Pack 1000pcs Case Cube 0.029m ³ 1.033cu ft 40HQ Cases 2208ctn
ZF1609-445W		<ul style="list-style-type: none"> 156x93mm 6.14x3.66in 145x82mm 5.71x3.23in 124x64mm 4.88x2.52in 50mm 1.97in 445ml 15.66fl.oz 	Case Pack 1000pcs Case Cube 0.039m ³ 1.377cu ft 40HQ Cases 1718ctn
ZF1512-400W		<ul style="list-style-type: none"> 148x118mm 5.83x4.65in 140x110mm 5.51x4.33in 115x90mm 4.53x3.54in 40mm 1.57in 400ml 14.08fl.oz 	Case Pack 1000pcs Case Cube 0.045m ³ 1.589cu ft 40HQ Cases 1344ctn
ZF1610-320W		<ul style="list-style-type: none"> 160x100mm 6.3x3.94in 147x91mm 5.79x3.58in 136x80mm 5.35x3.15in 31mm 1.3in 320ml 1.091fl.oz 	Case Pack 1000pcs Case Cube 0.037m ³ 1.295cu ft 40HQ Cases 2320ctn
ZF2020-970W		<ul style="list-style-type: none"> 203x203mm 7.99x7.99in 90x190mm 7.48x7.48in 180x180mm 7.09x7.09in 33mm 1.3in 970ml 34.14fl.oz 	Case Pack 500pcs Case Cube 0.05m ³ 1.821cu ft 40HQ Cases 1176ctn
ZF2212-1000W		<ul style="list-style-type: none"> 220x115mm 8.66x4.53in 20196mm 7.91x3.78in 188x83mm 7.40x3.27in 63mm 2.48in 1000ml 35.2fl.oz 	Case Pack 1000pcs Case Cube 0.07m ³ 2.450cu ft 40HQ Cases 910ctn
ZF4332-6700W		<ul style="list-style-type: none"> 430x320mm 16.93x12.60in 402x292mm 15.83x11.50in 351x238mm 13.82x9.37in 73mm 2.87in 6700ml 235.83fl.oz 	Case Pack 100pcs Case Cube 0.078m ³ 2.742cu ft 40HQ Cases 870ctn

矩形铝箔餐盒

Rectangles

型号 No.1	图片展示 picture	容器参数 Parameters	容器参数 Parameters
ZF3217-2780W		<ul style="list-style-type: none"> 320x165mm 12.6x6.5in 310x155mm 12.2x6.10in 260x118mm 10.24x4.65in 80mm 3.15in 2780ml 97.85fl.oz 	Case Pack 500pcs Case Cube 0.076m ³ 2.693cu ft 40HQ Cases 756ctn
ZF3222-1640W		<ul style="list-style-type: none"> 324x224mm 12.76x8.82in 309x209mm 12.17x8.23in 295x195mm 11.62x7.68in 31mm 1.22in 1640ml 56.89fl.oz 	Case Pack 200pcs Case Cube 0.06m ³ 2.109cu ft 40HQ Cases 1130ctn
ZF3226-2300W		<ul style="list-style-type: none"> 324x264mm 12.76x10.39in 292x232mm 11.5x9.13in 272x212mm 10.71x8.35in 40mm 1.57in 2300ml 80.96fl.oz 	Case Pack 100pcs Case Cube 0.044m ³ 1.545cu ft 40HQ Cases 1513ctn
ZF3226-2980W		<ul style="list-style-type: none"> 324x264mm 12.76x10.39in 292x232mm 11.5x9.13in 269x209mm 10.59x8.23in 52mm 2.05in 2980ml 104.89fl.oz 	Case Pack 100pcs Case Cube 0.045m ³ 1.594cu ft 40HQ Cases 1484ctn
ZF3226-3550W		<ul style="list-style-type: none"> 324x264mm 12.76x10.39in 262x232mm 10.31x9.13in 262x199mm 10.31x7.83in 63mm 2.48in 3550ml 124.96fl.oz 	Case Pack 100pcs Case Cube 0.045m ³ 1.594cu ft 40HQ Cases 1484ctn
ZF3226-5300W		<ul style="list-style-type: none"> 325x265mm 12.80x10.43in 298x238mm 11.73x9.37in 244x184mm 9.61x7.24in 105mm 4.13in 5300ml 186.55fl.oz 	Case Pack 50pcs Case Cube 0.029m ³ 1.025cu ft 40HQ Cases 2309ctn
ZF3727-5000W		<ul style="list-style-type: none"> 370x270mm 14.57x10.63in 340x241mm 13.39x9.49in 313x215mm 12.32x8.46in 72mm 2.83in 5000ml 175.99fl.oz 	Case Pack 100pcs Case Cube 0.021m ³ 0.731cu ft 40HQ Cases 3235ctn

异形铝箔餐盒

Heterotype

型号 No.1	图片展示 picture	容器参数 Parameters	容器参数 Parameters
ZX1717-360W		<ul style="list-style-type: none"> 173x169mm 6.81x6.65in 145x152mm 5.70x5.98in 135x140mm 5.31x5.51in 48mm 1.88in 360ml 12.6fl.oz 	Case Pack 500pcs Case Cube 0.039m ³ 1.377cu ft 40HQ Cases 1717ctn
ZX3220-360W		<ul style="list-style-type: none"> 324x196mm 12.75x7.71in 309x180mm 12.16x7.08in 30x170mm 1.18x6.69in 20mm 0.78in 360ml 12.6fl.oz 	Case Pack 200pcs Case Cube 0.52m ³ 1.836cu ft 40HQ Cases 1288ctn
ZX1818-360W		<ul style="list-style-type: none"> 176x176mm 6.92x6.92in 156x156mm 6.14x6.14in 135x135mm 5.31x5.31in 62mm 2.44in 360ml 12.6fl.oz 	Case Pack 1000pcs Case Cube 0.074m ³ 2.613cu ft 40HQ Cases 905ctn
ZX2112-360W		<ul style="list-style-type: none"> 210x119mm 8.26x4.68in 190x100mm 7.48x3.93in 158x88mm 6.22x3.46in 45mm 1.77in 360ml 12.6fl.oz 	Case Pack 500pcs Case Cube 0.033m ³ 1.165cu ft 40HQ Cases 2030ctn
ZX2923-360W		<ul style="list-style-type: none"> 290x231mm 11.41x9.09in 280x220mm 11.02x8.66in 252x198mm 9.92x7.79in 42mm 1.68in 360ml 12.6fl.oz 	Case Pack 500pcs Case Cube 0.052m ³ 1.836cu ft 40HQ Cases 1258ctn
ZX2517-360W		<ul style="list-style-type: none"> 252x170mm 9.92x6.69in mm in 215x130mm 8.46x5.11in 36mm 1.41in 360ml 12.6fl.oz 	Case Pack 500pcs Case Cube 0.075m ³ 2.648cu ft 40HQ Cases 893ctn
ZX2318-950W		<ul style="list-style-type: none"> 227x178mm 8.58x6.50in 206x151mm 8.11x5.94in 182x128mm 7.17x5.04in 46mm 1.81in 950ml 33.44fl.oz 	Case Pack 1000pcs Case Cube 0.053m ³ 1.865cu ft 40HQ Cases 1330ctn

Future food packaging field Be More Environmentally Friendly

未来的食品包装领域
属于更具环保意识的人

In the future of environmentally friendly packaging field, we create value and unlimited possibilities for our customers based on superior competitive products, innovative environmentally friendly production solutions and close partnerships.

在未来的环保包装领域里，我们以卓越的有竞争力的产品、革新的环保生产解决方案，以及密切的合作伙伴关系为基础，为客户创造需求之上的价值和无限的可能性。



Lightweight Material
材质轻盈

Good Ductility
延展性能好

High Temperature Resistant Heating
高耐温加热

High Barrier
高阻隔性

Ininitely Recyclable
可无限循环利用

Non-toxic And Odorless
无毒无味

We Use 100% Renewable Resources
我们使用100%可再生资源